

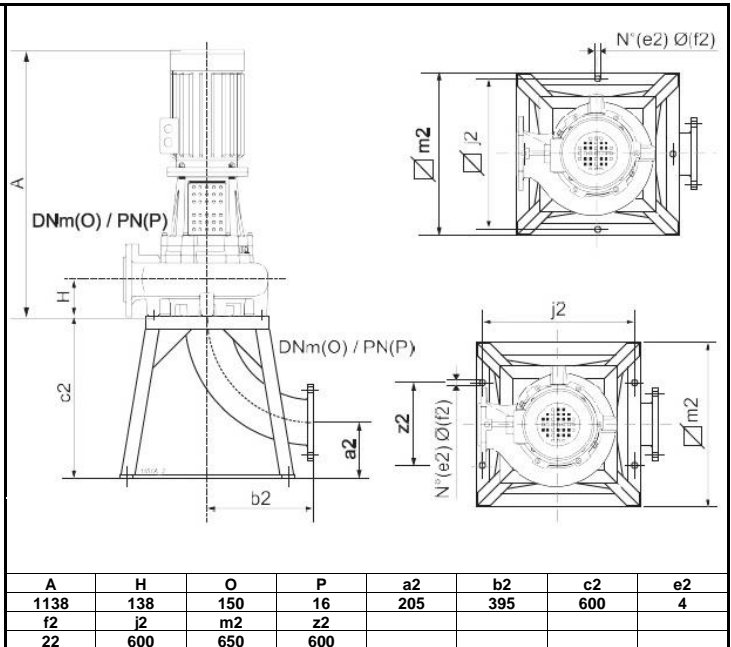

Type	ELECTRIC PUMP FOR WASTE WATER	Model	KONTROLL KC-60.150.4LA-T
------	-------------------------------	-------	-------------------------------------

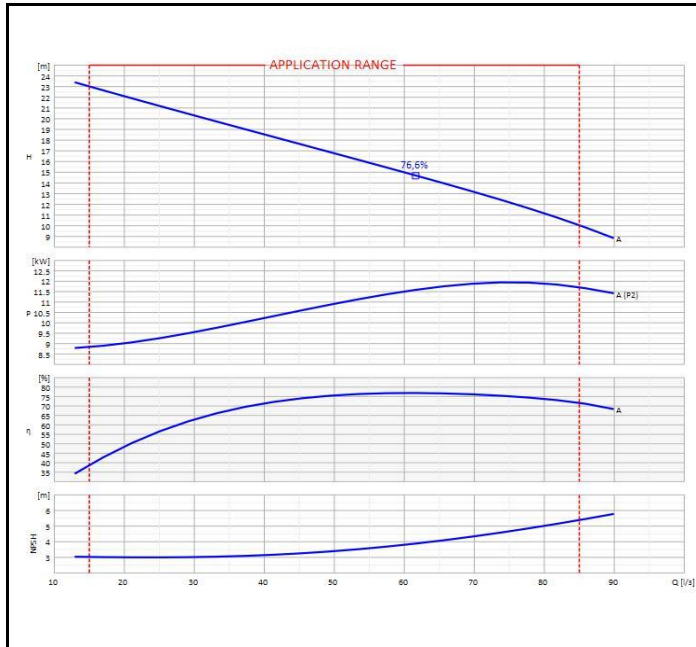

OPERATING DATA - ISO 9906:2012 3B -					CONSTRUCTION CHARACTERISTICS				
Q [l/s]	H [m]	P [kW]	η [%]	NPSH [m]	Delivery diameter		mm		
					150				
					Type of Impeller				
					Single channel				
					Moment of inertia				
					-				
					Installation Electric	Accessories	210	-	Kg
					Seal on pump side	Motor side	Mechanical		Mechanical
					Type of installation				
					-				

OPERATING LIMITS			OPERATING CHARACTERISTICS		
pumped liquid	Waste water		Service flow rate	-	-
Max. temperature of pumped liquid	60	°C	Service head	-	-
Maximum density	1	kg/dm ³	H (Q=0)	28,9	23
Maximum viscosity	1	mm ² /s	Hmax (Qmin)	15	85
Max. solid content	4	%	Qmin	Qmax	
Max. number of starts/hr	-		Power consumption at duty point	-	-
Free passage	100	mm	Max power consumption	11,9	kW
			Pump efficiency	-	-
			Overall efficiency	-	-
			Sense of rotation (*)	Clockwise	
			Number of pumps installed	Operating	Stand-by
				1	0

ELECTRIC PUMP MATERIALS		ELECTRIC MOTOR CHARACTERISTICS		
Delivery body	Cast iron	Nominal power	15	kW
Bearing support	Nodular cast iron	Rated frequency	50	Hz
Impeller	Cast iron	Rated voltage	400	V
Pump shaft	Stainless steel	Rated current	29	A
Flange bearing	Cast iron	No. Poles	4	1470
Oil box	Cast iron	Rotation speed		1/min
Lantern bracket	Cast iron	Efficiency class	IE3	
Wear ring	Steel/Rubber	Type of motor	3 ~	
Protective casing	Stainless steel	Efficiency 4/4 - 3/4	92,1 - 92,2 %	
Conductivity probe	Brass	Power factor 4/4 - 3/4	0,81	
Elastic ring	Steel	Is/In	7,8	2,2
Seal ring	Rubber	Ts/Tn		
Belleville washer	Stainless steel	Thermal protection	PTC	
Seal ring	Rubber	Insulation class	F	
Plug	Stainless steel	Protection class	IP55	
Mechanical seal on pump side	Ceramic/graphite	Mounting	V1	
Mechanical seal on motor side	Ceramic/graphite			