

HIDRO H

Unattended, multifunctional pumping stations

HA-CM technology

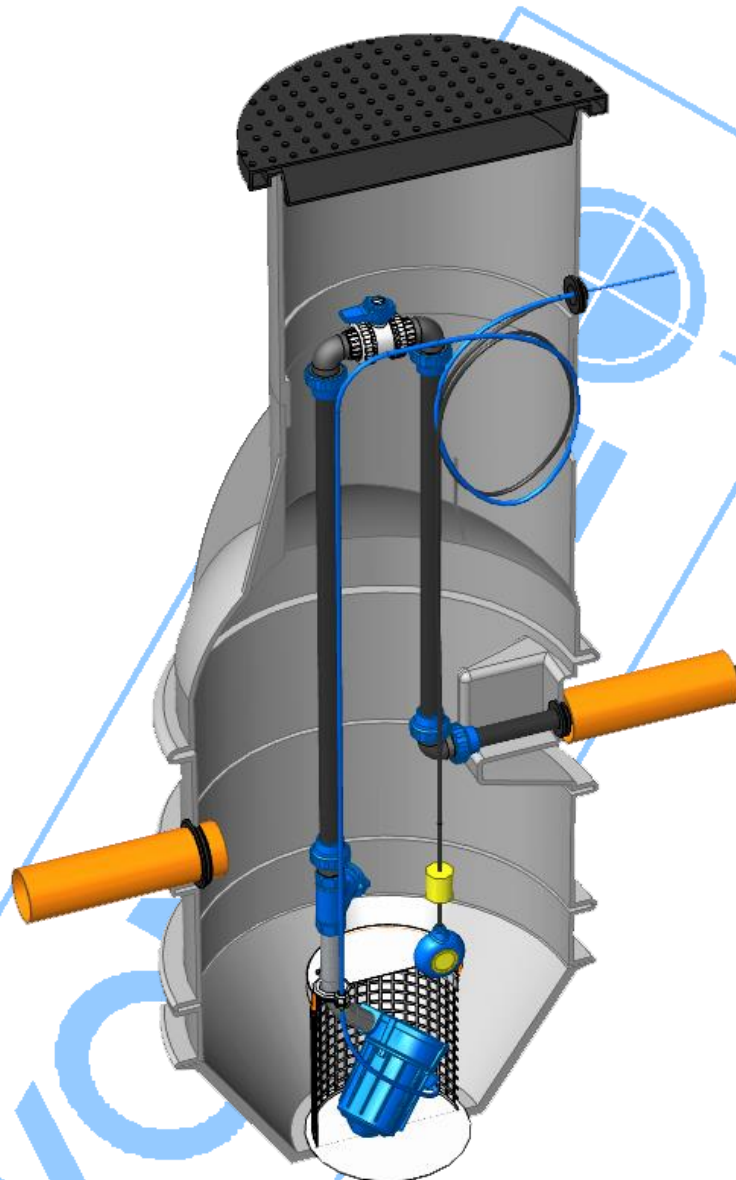

Unattended operation is provided.

The applied phase-separator protects against channel-foreign materials. The channel-foreign organic matters are discharged through the grid by the strong blending effect of the multifunctional pump. The multifunctional pump is controlled by a timing program adjustable optionally. The frequency of starts and the operation time can be adjusted optimally depending on the ratio of the communal sewage solid matter and liquid.

The pump units work with extremely high operation safety and long lifetime by applying trouble-free control and by excluding the channel-foreign materials.